

Specifications

320UPR	Receiver	UHF 240 Selectable Frequencies (794-805.950MHz) Dual-channel Receiver PLL Synthesized RF Squelch Level 13dB μ V Frequency Response 50Hz – 15kHz S/N Ratio >70dB "A" Weighted Audio Out MIC Level – Unbalanced – 3.5mm Mini-Jack Batteries 2 "AA" Alkaline (2 x 1.5V) - 3-4 hours runtime 2 "AA" rechargeable Ni-MH or Ni-Cd (2 x 1.2V) External Power 6VDC @ 0.5A Dimensions 2.87"W x 4.45"H x 1.59"D (73 x 113 x 40.5 mm) Weight Approx. 9.17oz (260g) w/batteries
30BT	Body-pack Transmitter	UHF 240 Selectable Frequencies (794-805.950MHz) PLL Synthesized RF Power 15mW Frequency Response 50Hz – 15kHz Max. Deviation \pm 40kHz @ 1kHz Modulation, MIC Input – 11dBm Batteries 2 "AA" Alkaline (2 x 1.5V) – 8-10 hours runtime 2 "AA" rechargeable Ni-MH or Ni-Cd (2 x 1.2V) Dimensions 2.52"W x 3.94"H x 1.06"D (64 x 100 x 27 mm) Weight Approx. 4.54oz (160g) w/batteries
30XT	Plug-In Transmitter	UHF 240 Selectable Frequencies (794-805.950MHz) Internal Antenna Max. Input level -7dBm RF Power 15mW Input Impedance 6k ohms Audio Adjust. Range -63dBm to 18dBm Battery 1 9V Alkaline – 6-8 hours runtime Dimensions 1.57"W x 1.57"H x 3.9"L (40 x 40 x 99 mm) Weight Approx. 6.4oz (181.4g) w/battery
30HT	Handheld Microphone/Transmitter	UHF 240 Selectable Frequencies (794-805.950MHz) PLL Synthesized RF Power 15mW Frequency Response 50Hz – 15kHz Max. Deviation \pm 40kHz @ 1kHz Modulation, MIC Input – 65dBm (dev \pm 5kHz) Batteries 2 "AA" Alkaline (2 x 1.5V) – 8-10 hours runtime 2 "AA" rechargeable Ni-MH or Ni-Cd (2 x 1.2V) Dimensions Φ 1.89" x 9.23"L (48 x 234.5 mm) Weight Approx. 4.23oz (245g) w/batteries

320 SYSTEM User's Guide

320UPR • 30BT • 30HT • 30XT ON-CAMERA UHF WIRELESS MICROPHONE SYSTEM



Due to constant improvements, specifications are subject to change without notice.

Azden Corporation, 147 New Hyde Park Road, P.O. Box 10, Franklin Square, NY 11010
 vox - 516.328.7500 • fax - 516.328.7506 • email - azdenus@azdencorp.com



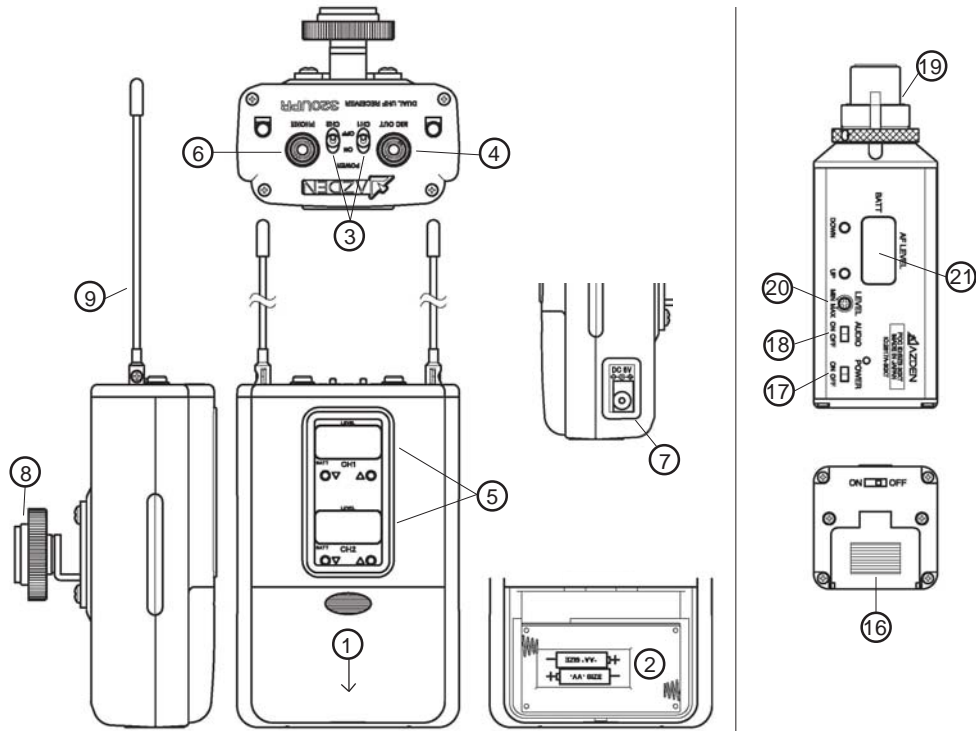

Operating the system

Because this is a frequency agile system, the receiver and transmitter must be on the same channel number. To change the channel number, use the tip of the provided tool and press the UP or DOWN button to the desired channel. Make sure both the receiver and transmitter are on the same channel.

320UPR Receiver

After installing new batteries, mount the receiver to your video camera with the supplied shoe mount or hook & loop fastener. Select one of the supplied cables and connect the output cable to the receiver and to the microphone input on the video camera. Switch Ch.1 and/or Ch.2 of the 320UPR to "ON" and the battery level indicator(s) should come on. If they do not, check the batteries. When the 320UPR receives a signal from the transmitter the reception level indicator will come on. If it does not, make sure both the receiver and transmitters are on matching channels.

30BT Transmitter

Plug in the supplied lapel microphone and clip it to your subject. The microphone should be placed 4-12 inches from your subject's mouth. Clip the transmitter to a belt using the supplied belt-clip or place it in a pocket. Switch the 30BT to "ON" and the battery level indicator should come on. If it does not, check the battery. Have someone speak into the microphone as you monitor the sound through the receiver's phone output. If the sound is distorted lower the MIC input level on the transmitter. If there is not enough volume raise the MIC input level on the transmitter.

30XT Transmitter

Switch the transmitter to "ON" and the battery level indicator should come on. If it does not, check the battery. Have someone speak into the microphone as you monitor the sound through the camera's monitor output. If the sound is distorted lower the level control on the transmitter. If there is not enough gain raise the level control on the transmitter.

30HT Transmitter

Switch the transmitter to "ON" and the battery level indicator should come on. If it does not, check the battery. Have someone speak into the microphone as you monitor the sound through the camera's monitor output. If the sound is distorted lower the level control on the transmitter. If there is not enough gain raise the level control on the transmitter.

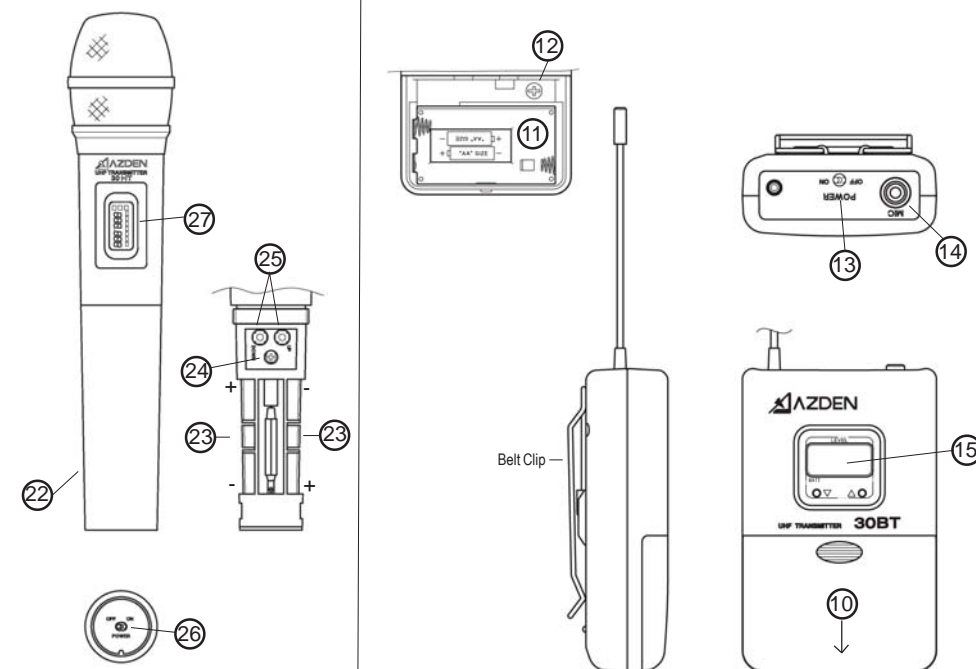

Important information

Licensing of this, or any Azden wireless equipment is the user's responsibility. The ability to receive a license depends largely on the user's classification, application and frequency. Contact the appropriate agency (FCC in the US) for further information.

These devices comply with Part 15 of the FCC Rules. Operation is subject to the following two conditions: (1) These devices may not cause harmful interference, and (2) These devices must accept any interference received, including interference that may cause undesired operation.

NOTE: The manufacturer is not responsible for any radio or TV interference caused by unauthorized modifications to this equipment. Such modifications could void the user's authority to operate the equipment.

These devices and their antenna(s) must not be co-located or operated in conjunction with any other antenna or transmitter.

(21) LCD Display:

The display will light up when the power is turned "ON". The LCD display shows the following information.

Channels number: 001 to 240

Battery Condition: Using a 3 step indicator – 1(Low) to 3 (High)

To change the channel number, use the tip of the tool provided and press the UP or DOWN button until the desired channel number appears (001 to 240). Once the desired channel number has been selected on the transmitter, set the receiver to the same channel number.

HANDHELD MICROPHONE/TRANSMITTER (30HT)

(22) Remove the battery compartment cover by rotating it counterclockwise and sliding it down.

(23) Insert two fresh Alkaline "AA" batteries into the compartment. Make sure the battery polarity is correct as marked inside the battery compartment.

In the battery compartment you will also find:

(24) MIC LEVEL Control

The MIC LEVEL control enables you to adjust the audio level of the microphone. Using the supplied tool, turn the dial clockwise to increase, or counterclockwise to decrease the microphone's audio level.

(25) UP/DOWN Channel Buttons

To change the channel number, use the tip of the tool provided and press the UP or DOWN button until the desired channel number appears (001 to 240). Once the desired channel number has been selected on the transmitter, set the receiver to the same channel number.

(26) POWER

Switches the transmitter "ON" or "OFF".

(27) LCD Display:

The display will light up when the power is turned "ON". The LCD display shows the following information.

Channel number: 001 to 240.

Battery Condition: Using a 3 step indicator - 1 (Low) to 3 (High)

Thank you for purchasing Azden's 320 wireless microphone system. Depending on which system you ordered this package will contain one or more of the following components: the 320UPR receiver, the 30BT body-pack transmitter with EX-503L lavalier microphone, the 30XT XLR plug-in transmitter and/or the 30HT handheld microphone transmitter. This equipment is designed primarily for video cameras but is usable with most electronic components having a microphone level input. The 320UPR allows you to "receive" audio from two different transmitters simultaneously.

RECEIVER (320UPR)

(1) Remove the battery compartment lid by sliding it down.

(2) Insert two fresh alkaline "AA" batteries into the compartment. Make sure the battery polarity is correct as marked inside the battery compartment.

(3) POWER (one switch for each channel)

Switches the receiver CH1 and/or CH2 "ON" or "OFF".

(4) MIC OUT jack:

The 320UPR is supplied with both a mini-to-mini and a mini-to-dual XLR cable.

For mini jack microphone inputs: Use the supplied mini-to-mini cable. Plug one end of the cable into the receiver and the other end of the cable into the microphone input of the video camera.

For 3-pin XLR microphone inputs: Use the supplied mini-to-dual XLR cable. Plug the mini-plug end of the cable into the receiver (use the screw-down sleeve to secure it to the receiver) and plug the XLR ends of the cable into the microphone inputs of the video camera. Ch.1 is on the "Tip" connector, Ch.2 is on the "Ring".

(5) LCD Display:

There are two displays, one for CH1 and one for CH2. The display for each channel will light up when the power for that channel is turned "ON". The LCD displays show the following identical information.

Channel Number: 001 to 240

Battery Condition: Using a 3-step indicator - 1 (Low) to 3 (High)

Reception Level: Using a 4-step indicator - 1 (Low) to 4 (High)

To change the channel number, use the tip of the tool provided and press the UP or DOWN button until the desired channel number appears (001 to 240). Once the desired channel number has been selected on the receiver, set the transmitter to the same channel number.

NOTE: When using two transmitters with the 320UPR please do the following:

A) Make sure that you use 2 different channel numbers that are at least 10 numbers apart. This will prevent possible crosstalk between the 2 channels being used. For example: If you use channel number 10 for one transmitter, use channel number 20 for the other transmitter. The 2 channels on the receiver must also be set on the numbers 10 and 20.

B) The system will operate properly if both transmitters are in close proximity to each other, however make sure that both transmitters are at least 10 feet away from the receiver, this will prevent the frequencies from overlapping.

(6) PHONE jack:

Plug a stereo headphone into this jack to monitor sound - Ch. 1 will be heard on the left, Ch. 2 on the right.

(7) DC 6 Volt Input: An optional charger/power supply and rechargeable batteries are available for the 320UPR. For additional information or to order these products please visit the Azden website at www.azdencorp.com or contact your Azden dealer.

NOTE: Using a power supply of the wrong voltage/current may damage the unit and void the warranty.

(8) Shoe Stand:

Attach the 320UPR to the shoe-mount of the video camera by sliding it into place. Turn the thumbwheel clockwise to tighten. Reverse this procedure to remove the 320UPR from the camera.

(9) Antennas: For best reception the antennas should be pointed in an upward fashion. Use caution, and do not force them into this position.

BODYPACK TRANSMITTER (30BT)

(10) Remove the battery compartment lid by sliding it down.

(11) Insert two fresh "AA" batteries* into the compartment. Make sure the battery polarity is correct as marked inside the battery compartment.

In addition to the battery, inside the battery compartment you will find:

(12) MIC Input LEVEL Control

This control enables you to adjust the input level of the microphone. Using the supplied tool, turn the dial clockwise to increase, or counterclockwise to decrease the input level.

(13) POWER

Switches the transmitter "ON" or "OFF".

(14) MIC Input Jack

Plug the supplied EX-503L microphone into the MIC input jack and tighten the collar until snug (DO NOT OVERTIGHTEN). In addition to the EX-503L, other lapel and/or headset microphones with 3.5mm mini plugs can also be used with the 30BT.

(15) LCD Display

This display shows the following information.

Channel Number: 001 to 240

Battery Condition: Using a 3 step indicator - 1 (Low) to 3 (High)

To change the channel number: Use the tip of the tool provided and press the UP or DOWN button to the desired channel, number appears (001 to 240). Once the desired channel number has been selected on the transmitter, set the receiver to the same channel number.

*While Alkaline batteries are preferred, you can use rechargeable Ni-Cd or Ni-MH batteries.

XLR PLUG-IN TRANSMITTER (30XT)

(16) Open the battery compartment lid by sliding it down and lifting it up.

Insert a 9 volt Alkaline battery into the compartment. Make sure the battery polarity is correct as marked inside the battery compartment.

(17) POWER

Switches the transmitter "ON" or "OFF".

(18) AUDIO

Prior to first turning the 30XT "ON" it is best to set the AUDIO switch to "OFF". When you are ready to begin transmitting, switch to "ON". The "OFF" position acts as a "mute" that maintains the RF signal but turns off the audio.

(19) MIC Connector/Locking Ring

This 3-pin XLR connector is the microphone input. Any low impedance microphone with a corresponding connector can be attached here.

Once the microphone is plugged into the 30XT the locking ring should be rotated clockwise until snug. To remove the microphone, first rotate the locking ring counterclockwise and then, while pressing the XLR release, pull the microphone away from the 30XT.

(20) MIC Input LEVEL Control

The MIC input LEVEL control enables you to adjust the input level of the connected microphone. Using the supplied tool, turn the dial clockwise to increase, or counterclockwise to decrease the input level